

## ARCTIC TRUCKS AT44 FORD SUPER DUTY 4X4

The legendary off-road performance that Arctic Trucks has built its reputation on meets North America's most rugged and reliable pickup truck. We've designed our AT44 Ford Super Duty with function first. The combination of off-road capability and payload capacity makes this truck a versatile tool for logistics operators, remote construction projects, Search & Rescue, exploration, surveying, or any critical missions in remote and demanding terrain. Our proprietary, DOT compliant 44" Arctic Trucks/Nokian tires provide unmatched floatation for superior traction in snow, mud, and over rocky terrain, while allowing normal highway travel between your off-road expeditions. Available with a multitude of options such as a four-link rear air suspension, auxiliary fuel tanks, central tire inflation, and multiple bed options, the AT44 Super Duty is custom built to fulfill the needs of your mission.

**BASE PACKAGE PRICE = \$68,935 USD / \$93,224 CAD**  
(EXCLUDING BASE VEHICLE)

This is not your average lifted truck. In fact, it's hardly lifted at all. Arctic Trucks takes great measures to re-engineer the body and frame to minimize suspension lift and keep the truck's center of gravity low. Ensuring equalized ground pressure on each tire when off-road, this approach also provides a confident and comfortable ride with less driver fatigue and improved accessibility.

Our optional four-link rear suspension offers up to 12" of suspension travel, dramatically improving traction over uneven surfaces and improving comfort when traveling over rough roads. Proprietary shocks and springs and carefully selected suspension geometry modifications expand our truck's performance envelope off-road without compromising versatility.

An extensive option list covers the needs of a wide range of applications. Looking for something you don't see? Talk with us about building something unique for you - we'll utilize our decades of experience to make sure you end up with the right tool for the job.

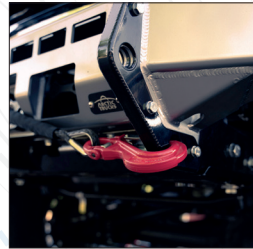
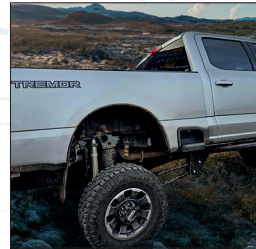

### STANDARD FEATURES

- Arctic Trucks AT44 frame & body conversion
- Arctic Trucks 17"x15" steel wheels
- 44"x18" Arctic Trucks/Nokian Hakkapeliitta radial tires
- Arctic Trucks 3" lift suspension
- Fox/ATS steering damper
- Aluminum side steps with integrated mud flaps
- Front bumper modifications and Arctic Trucks light bar
- Arctic Trucks AT44 branding package

### OPTIONAL FEATURES

- Central Tire Inflation System (CTIS) with in-cab electronic control
- Axle Upgrade to Dana 60 front axle with Eaton Truetrac differential and Dana M275 rear axle with e-lock differential, regared to 4.88 ratio

- Rear axle relocation available with aftermarket bed options
- Four-link rear suspension with coil over-spring and/or air suspension configurations
- Arctic Trucks 3 piece aluminum wheels
- Switch Pros electronic accessory power and switching system
- VisionX lighting includes 8.7" ADV spot lights, 20" Shocker bar, amber fog and scene lights
- UpTop Overland roof rack
- ComeUp 12.5K and 16.5K winch options
- Webasto engine coolant heater
- Arctic Trucks embroidered seats
- Dissent Off-Road / Arctic Trucks hybrid aluminum/steel front bumper
- Custom auxiliary fuel tanks
- Nuthouse Industries custom aluminum flat bed
- Arctic Trucks custom rear bumper with three recovery points
- Front mounted crane

### DIMENSIONS

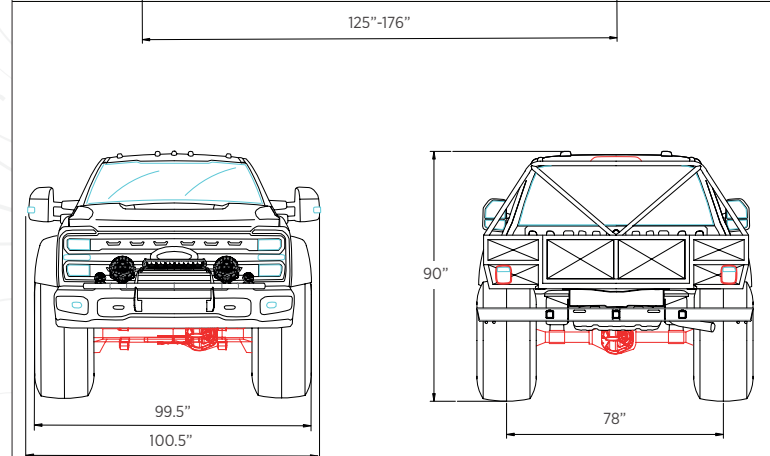
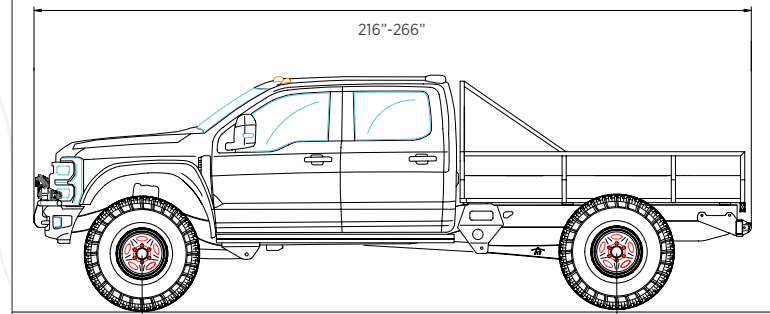

Specification, pricing & dimensions are subject to change

### BUILD COMPLEXITY

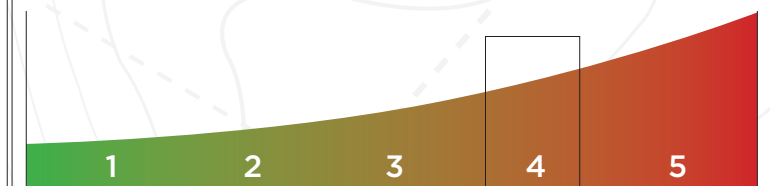

[www.arctictrucks.us](http://www.arctictrucks.us)

351 Lexington Ave. Cheyenne, WY 82007  
 307-316-3785 - sales@arctictrucks.us  
 Follow us @ArcticTrucksNorthAmerica



Distributor Contact Information