

ARCTIC TRUCKS AT44 FORD SUPER DUTY 6X6

Engineered for the most demanding deep field missions and operation, Arctic Trucks offers the ultimate 6x6 conversion. The AT44 Super Duty 6x6 leverages decades of experience in 6x6 suspension and driveline design and vehicle construction to bring you this incredibly rugged platform, capable of controlling heavy payloads with ease while boasting incredible off-road performance. The conversion begins with a Ford F350-F600 Cab Chassis, re-engineered with a fully boxed frame to prepare for the addition of the 2nd rear axle. The rear suspension is our proprietary 8-link design for improved articulation, stability, and load carrying capacity. A range of tires are available for different uses, including Continental MPT tires and our Arctic Trucks/Nokian 44" tire.

BASE PRICE = \$229,478 USD / \$310,115 CAD (EXCLUDING BASE VEHICLE)

The addition of a second rear axle improves floatation and stability over snow and rugged terrain with heavier payloads. The second driven axle also adds to the truck's snow/ice towing capabilities, making this platform a true workhorse in the most demanding situations.

Uptime and reliability are critical to any mission. Arctic Trucks' design philosophy puts serviceability as a top priority – despite extensive modifications, our trucks require very little additional maintenance and add only a handful of wear items.

A wide variety of options and upgrades are available to tailor the 6x6 to your needs. Looking for options we have yet to offer? Talk with us about building something new. We've taken wheeled vehicles to places nobody else has. We'll make sure you have with the right tool for the job.



STANDARD FEATURES

- Fully boxed frame
- Arctic Trucks 8-link rear air spring suspension
- Arctic Trucks axle-mounted, locking transfer case
- Arctic Trucks AT44 fender flares & body conversion
- Arctic Trucks 3" lift suspension
- 41 - 44" tire options on steel or aluminum wheels
- Rear axles upgraded to Dana M275 (e-Locker) or M300 (Limited slip)
- Front axle upgraded to Dana 60 with Eaton Truetrac differential
- Front and rear axles regeared to 4.88:1 ratio
- Upgraded OE 4x4 transfer case
- Fox ATS Steering Damper
- Aluminum side steps with integrated mud flaps
- Front bumper modifications and Arctic Trucks light bar
- Arctic Trucks AT44 branding

OPTIONAL FEATURES

- Frame extension
- Central Tire Inflation System (CTIS) with in-cab electronic control
- Switch Pros electronic accessory power and switching system
- VisionX lighting includes 8.7" ADV spot lights, 20" LED Shocker bar, fog lights and scene lights
- UpTop Overland roof rack
- ComeUp 12.5K and 16.5K winch options
- Webasto engine coolant heater
- Dissent Off-Road / Arctic Trucks hybrid aluminum/steel front bumper
- Custom auxiliary fuel tanks
- Nuthouse custom aluminum flat bed
- Arctic Trucks custom rear bumper with three recovery points
- Front mounted crane
- Crawler gear
- Engine and transmission skid plates
- Arctic Trucks embroidered seats



DIMENSIONS & SPECIFICATIONS

Curb Weight (Approx)	9,500 lbs
Payload (Approx)	9,000 lbs

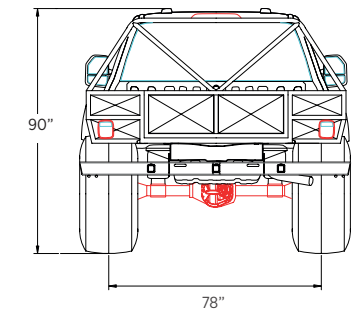
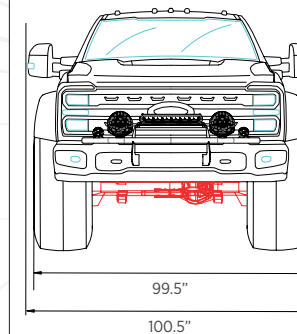
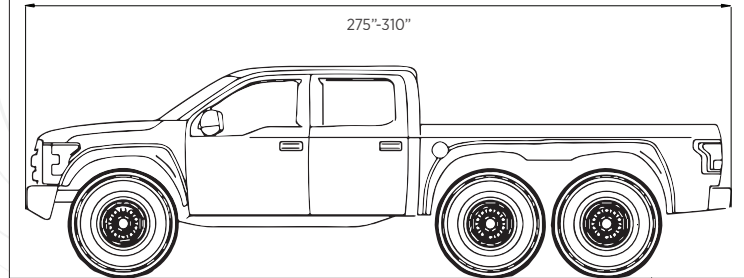

Specification, pricing & dimensions are subject to change

www.arctictrucks.us

351 Lexington Ave. Cheyenne, WY 82007
 307-316-3785 - sales@arctictrucks.us
 Follow us @ArcticTrucksNorthAmerica



Distributor Contact Information

BUILD COMPLEXITY

