

## AT40/AT42 FORD SUPER DUTY

Proven solutions, signature design. Arctic Trucks' new AT40 and AT42 Super Duty trucks offer a generous set of standard features and long list of available options and configurations for your bespoke build. More than just a suspension system or just a body kit, it's the whole package; a carefully engineered suite of components to elevate Ford's venerable Super Duty trucks to a new level of capability, convenience, and style.

Thousands of miles of testing and successful expeditions in the Arctic and Antarctica have showcased the capabilities and brute strength of Arctic Trucks' Super Duty trucks since we started their production in 2022. The technologies, components, and quality that took these AT44 vehicles to the most remote stretches of terrain are now available in a pair of premium, capable, and attractive new models; AT42 and AT40 Super Duty.

Arctic Trucks' DNA runs strong in these trucks. Built in, not up, our vehicles fit larger tires with lower lifts, keeping the trucks' center of gravity low and improving day-to-day convenience. Don't let the ride height deceive you, our suspension systems offer between 10" and 12" of travel, with class leading ground clearance.

Designed to accommodate a range of wheels and tires, AT40 and AT42 can be built to your preferences. A long list of options including your choice of leaf spring or 4-link rear suspension, different lift heights, and premium accessories make these truly bespoke builds. What comes standard is the signature Icelandic look and a premium quality suite of components to help you Explore without Limits.

#### STANDARD FEATURES: \*

- Arctic Trucks / Radflo 2.0" external reservoir shocks
- Front coil springs with 1.5" lift
- Radius arm drop brackets
- Extended OE track bar
- AT40 frame and body conversion
- Custom rear leaf springs, matched for payload and desired usage
- Revised front and rear bump stop mounting
- Arctic Trucks fender flare set with fender liners
- Rear brake hose relocation bracket
- Extended front brake hoses
- AT40/AT42 Wide Body

#### Optional Features:

- Arctic Trucks bespoke leather interior
- 3" front lift
- Arctic Trucks / Radflo 2.5" Adjustable External Reservoir Shocks
- Arctic Trucks / Dissent Off-Road hybrid aluminum/steel front bumper
- Arctic Trucks CTIS compatible, 12" wide 3-piece wheels
- Arctic Trucks branded VisionX front and side lighting package
- Various Come-up winch options
- Central Tire Inflation system
- Dana 60 front axle upgrade and various regearing and differential options
- Rear multi-link suspension with air or coil spring options
- Arctic Trucks running boards with extended mudflaps
- Interior upgrade with Arctic Trucks' branded interior trim
- Various roof rack options
- Aftermarket and OE Bed Options

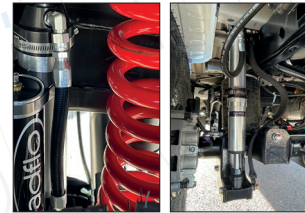

#### DIMENSIONS

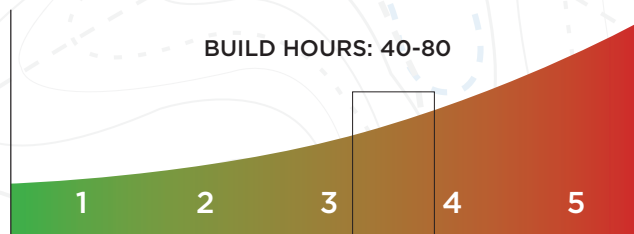
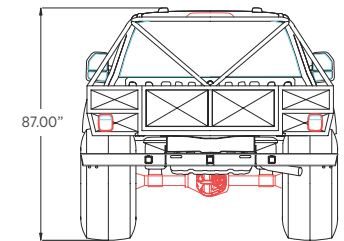
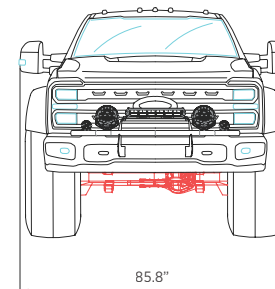
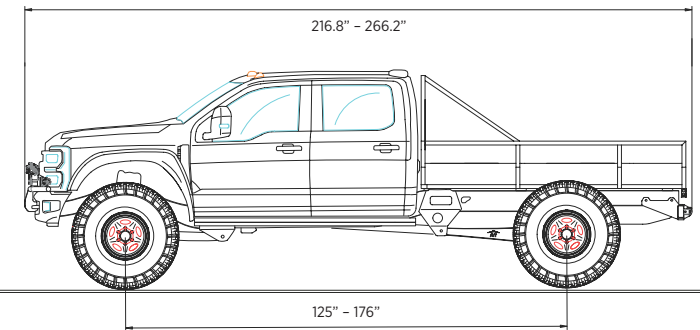

[arctictrucks.us](https://arctictrucks.us)

[sales@arctictrucks.us](mailto:sales@arctictrucks.us)



[arctictrucksnorthamerica](https://www.facebook.com/arctictrucksnorthamerica)

*\*Specification, pricing, weights and dimensions may vary*